aeco TRS 4.4

1Pcs / 1 Set

AT4-1812G / 5 pole / Gold plated / US\$50
AT4-1812R / 5 pole / Rhodium plated / US\$60
AT4-1812S / 5 pole / Silver plated / US\$50

Concept

One piece conductor is manufacture via CNC machining, in order to reduce the loss of signal that between each different conductors.

Soldering pins of each channel and cable core wires are parallel oriented, it is far more convenient for soldering.

4 pole metal conductors (right, left, positive, negative) with the same cross-sectional area.

Shell between body isolate by insulator material. Depends on the method of processing, it can choose to make the shell be a conductor.

The conductor is made from high-purity tellurium copper without nickel base.

By using highest quality of design techniques and material to provide customer who has "Hi-End" requirement.



Description

Mechanical structure :

4.4mm metal body with five parts , Tip Pin ,center ring, end sleeve .

Each metal part is separate by Nylon insulation.

There' s a hole between the contact pin and body structure.

To put the fillers into the gap of the body from the hole.

Use the POM latch through to fix the body.

The body and the shell locked by screwing.

POM sleeve is fixed with end of shell by using screw.



aeeco TRS AT4-1812G

Note :

This product include: screw for cable 3 mm*1pcs and 4 mm*1pcs.

Over soldering time may cause expands or damage of insulation.

When soldering the contact pin ,please follow up our suggested temperature.



aeeco TRS AT4-1812R

Assembly :

1. We recommend to peel off the cable jacket and per conductor wire insulation.
2. Depends on cable size to decide whether use sleeve (ID 4.5mm) [311], or without sleeve (ID6.5MM) [301]. Then through into cable.
3. Soldering each channel conductors.
4. The interface of each channel and cable polarity , please find the detail as below picture.
5. Lock the shell and body [203].
6. Please lock the cable and shell with a screw M3x4mm [321] or M3x3mm [322].



aeeco TRS AT4-1812S

Finish:

AT4-1812G

Tip Pin : 10u" Gold plating (no nickel base).
Center ring: 10u" Gold plating (no nickel base).
End sleeve: : 10u" Gold plating (no nickel base).

AT4-1812R

Tip Pin : Rhodium plating (no nickel base).
Center ring: Rhodium plating (no nickel base).
End sleeve: : Rhodium plating (no nickel base).

AT4-1812S

Tip Pin : 120u" Silver plating (no nickel base).
Center ring: 120u" Silver plating (no nickel base).
End sleeve: : 120u" Silver plating (no nickel base).

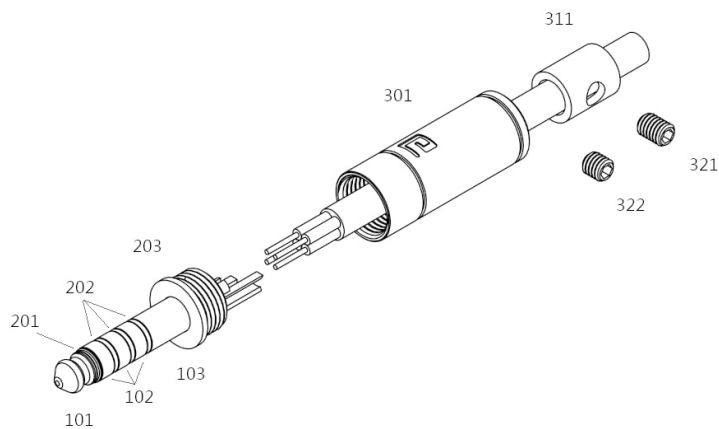

Insulator : None.
Head lock : None.
Shell : None.
Sleeve : None.
Screw : None.

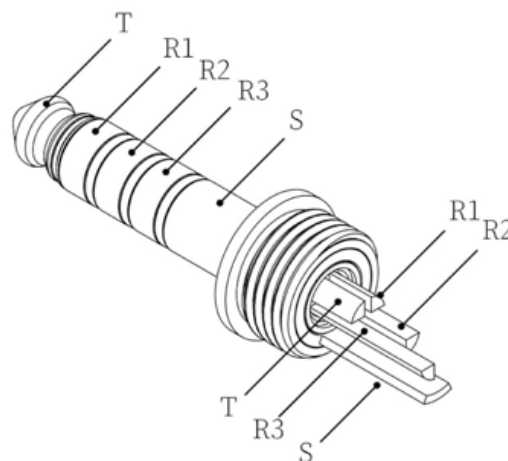

Electrical Characteristics:

Contact resistance < 1.0 mOhm

Dimension:

Biggest OD : 8.90 mm
Total Length : 43.5mm
Cable hole :
Sleeve contained in shell is 4.5mm.
Sleeve not contained in shell is 6.5mm.

Package:

Vacuum Bag(1Pcs)
place in the sponge then pack in the vacuum bag.

Recommend soldering temperature:

Temperature Soldering Iron, please keep 340 °C within 2~3 second
Temperature Soldering Iron, please keep 360 °C within 3~5 second

Product production process comply with RoHS.
This product obtains R.O.C. Patent No. M638409.

Material:

Tip Pin : Tellurium Copper (#C14500 / copper contains over 99%)
Center ring: Tellurium Copper (#C14500 / copper contains over 99%)
End sleeve: : Tellurium Copper (#C14500 / copper contains over 99%)
Insulator : Nylon (PA66)
Lock head : POM (Black)
Shell: Stainless steel (SUS304)
Sleeve: POM (Black)
Screw : Stainless steel (SUS304)