

FURUTECH

PURE TRANSMISSION



NCF material

CF-202 NCF(R) High End Performance Banana Connector

Soldering or Set Screw wire termination



Furutech introduces the CF-202 NCF top-of-the-line Banana connector. This is Furutech's first high-performance Banana connector to feature Nano Crystal² Formula (NCF). This material is the cumulative result of Furutech's 30 plus year effort to eliminate electrical and mechanical resonance from signal and power transmission in high performance audio and video applications. Offering a dramatic reduction in noise, improved imaging, and focus, and improved sound staging, the CF-202 NCF will take your listening enjoyment to the next level.

NCF damping fixed ring -Nano Crystal² Formula (NCF).

Incorporated into selected Furutech products, NCF features a special crystalline material that has two 'active' properties. First, it generates negative ions that eliminate static. Second, it converts thermal energy into far

infrared. Furutech combines this remarkable material with nano-sized ceramic particles and carbon powder for their additional 'piezoelectric effect' damping properties. The resulting Nano Crystal² Formula is the ultimate electrical and mechanical damping material. Created by Furutech, it is found exclusively in Furutech products.

Furutech's Two-Stage Cryogenic and Demagnetization Alpha Process

Using cutting-edge technology and materials, Furutech developed a low-temperature two-stage process that significantly improves every facet of audio and video performance. The treatment begins during the manufacturing process with a deep, conditioning cryogenic freeze of all metal parts. Using high-end refrigerants -- liquid N₂ or He -- Furutech achieves temperatures of between -196 to -250°C. The treated parts actually change their molecular structure at these extremes of temperature relieving internal stress. The molecules bond together more tightly, and the overall structure becomes more stable. This improves electrical conductivity and so power and signal transfer.

Step two in the Alpha Process exposes these same parts to the patented Ring Demagnetization treatment.

Ordinary high-power magnets used for this purpose often increase magnetic effects; they leave some areas more magnetized than others. This patented process uses controlled attenuation to completely eliminate magnetization for immediately more vivid and colorful improvements. Ring Demagnetization further enhances conductivity of all treated materials.

ALL metallic parts used in Furutech products go through the Alpha Process treatment to keep all connectors, conductors, and metal parts in a perfect stress-free, stable, and highly conductive state.

Features

1. α (Alpha) Pure Copper rhodium-plated one-piece center conductor.
2. NCF damping ring for the Pin is formed with a multi compound resin. This resin incorporates Liquid Crystal Polymer (LCP), nano-sized ceramic particles and carbon powder for their additional "Piezo Effect" damping properties. As well as Furutech's NCF (Nano Crystal² Formula) which eliminates static, "interconverts" thermal, mechanical, and electrical energy and damps vibrations. NCF delivers improvements in the depth and focus of the sound stage, harmonics and tonal balance. Low frequencies are cleaner, with a greater sense of definition made possible by a lowered noise floor.

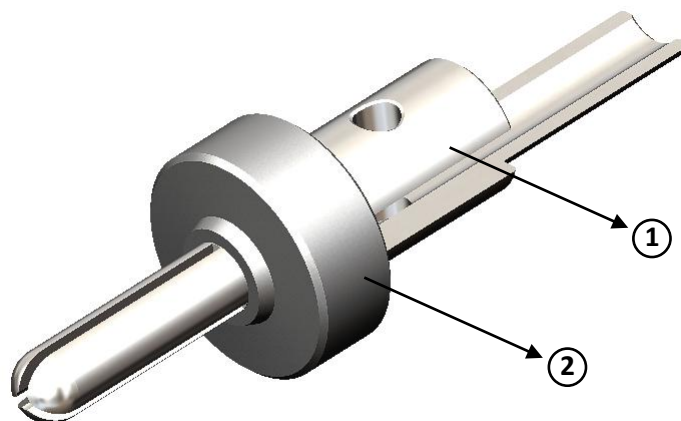

- Housing: Multilayer hybrid NCF carbon housing composed of an outer hard clear coat over with another layer of Hybrid NCF Silver plated 3k carbon fiber on a nonmagnetic stainless-steel Housing. The best of damping and insulation materials improve frequency extension and tonal balance.

Housing multilayer structure description

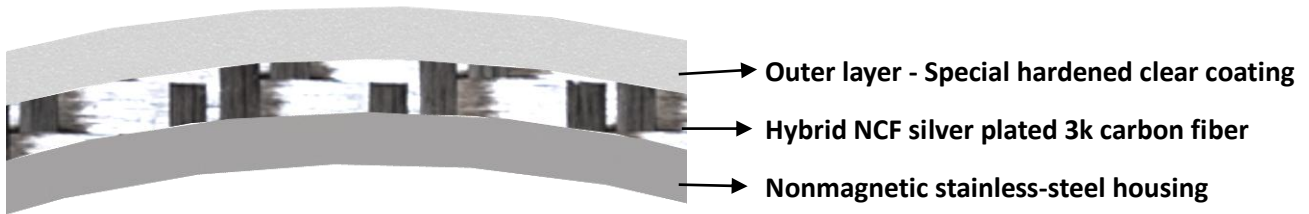

- Knurling end housing.
- End housing insulation ring.

Non-magnetic SUS set screw construction design ¹

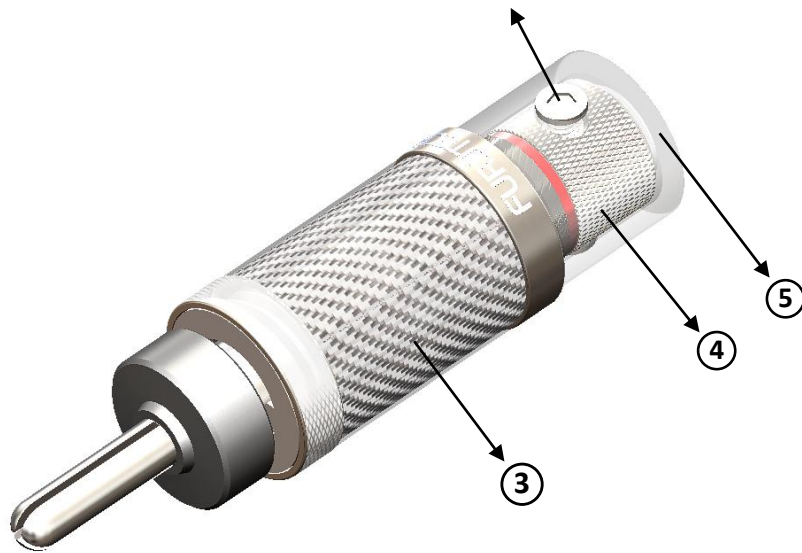

- α (Alpha) Nonmagnetic stainless-steel body.
- Special stainless-steel clamp compacts stranded wire for improved connection.

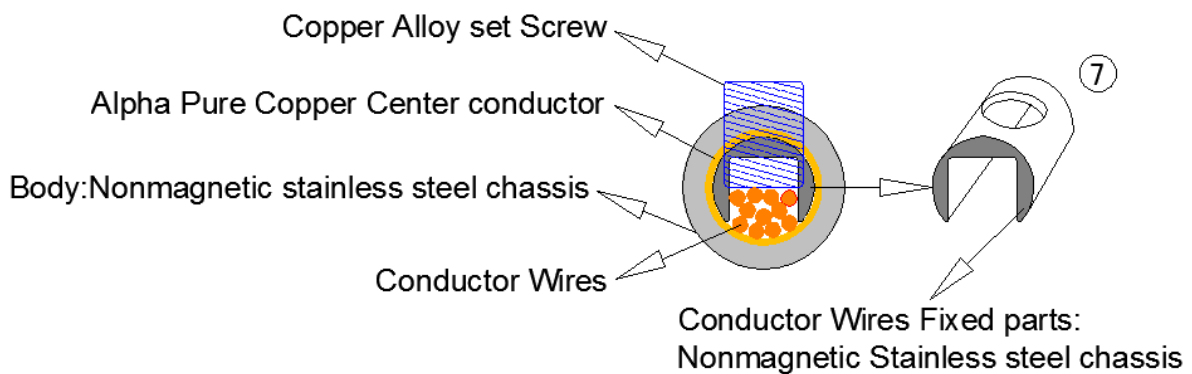

Specially engineered Conductor wires fixed construction

Specially engineered set screw construction to ensure firm contact with Alpha Pure Copper conductor

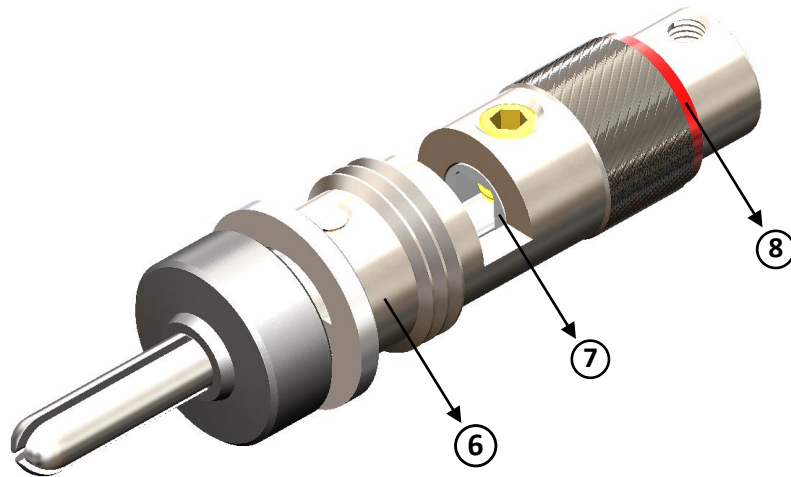

- 8. Aluminum color ring
- 9. Center conductor locking set.

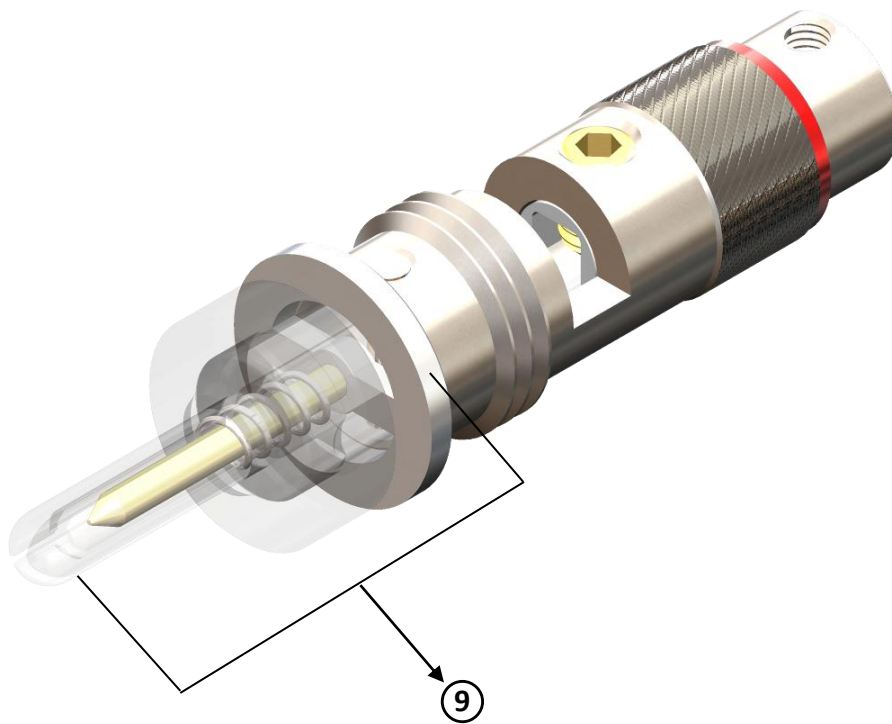

- 10. Conductor wire fixed by set screw or soldering.
- 11. Specially designed fixed wire construction to ensure the stability of the conductor's contact.

***Specially engineered dual structure to ensure firm contact
Conductor wire fixed by screw set or soldering***

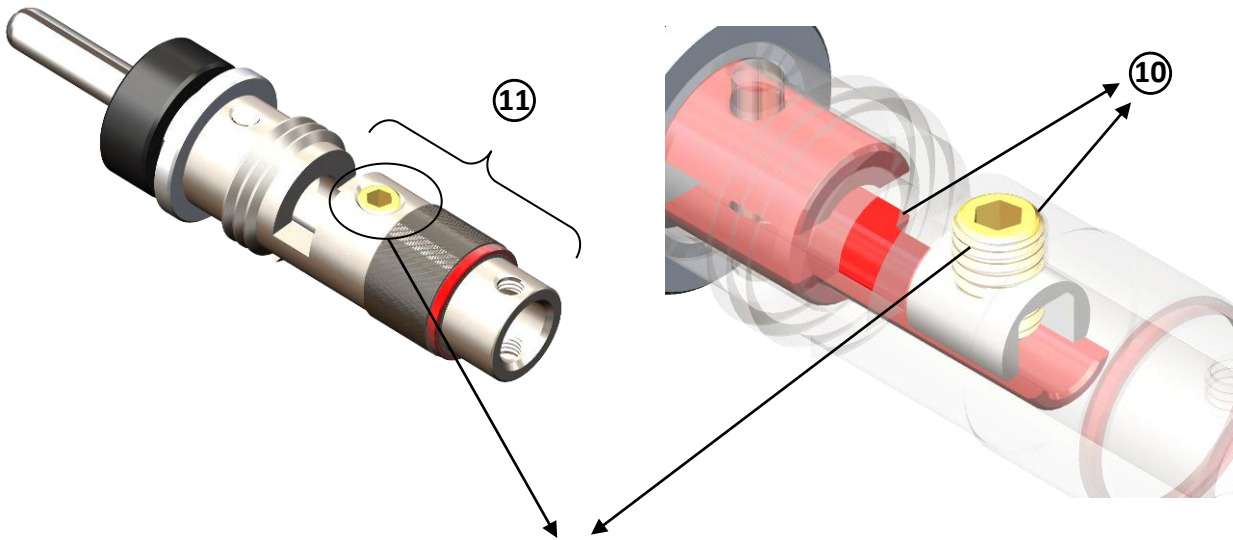

Copper alloy set screw (H2.0)²

Specifications

- Specified for wire diameters max. 5.5mm
- Dimensions: 15.2mm diameter x 60.5mm overall length approx.
- Net Weight: 33.4g approx.

Accessories

- 2mm hex head screwdriver (H2.0)*1 PC
- Hex socket set screws (M4x4)*2pcs/Set

Note: Too much torque when tightening of the screws may damage them. Recommended torque values for tightening the screws are as follows.

Conductor wire set screw: 30cN • m (3.0 kgf.cm) Approx.

End ring fixing screw: 8cN • m (3.0 kgf.cm) Approx.