

LME49610

LME49610 High Performance, High Fidelity, High Current Audio Buffer



Literature Number: SNAS435A

LME49610

High Performance, High Fidelity, High Current Audio Buffer

General Description

The LME49610 is a high performance, low distortion high fidelity 250mA audio buffer. The LME49610 is designed for a wide range of applications. When used inside the feedback loop of an op amp, it increases output current, improves capacitive load drive, and eliminates thermal feedback.

The LME49610 offers a pin-selectable bandwidth: a low current, 120MHz bandwidth mode that consumes 13mA and a wide 200MHz bandwidth mode that consumes 19mA. In both modes the LME49610 has a nominal 2000V/μs slew rate. Bandwidth is easily adjusted by either leaving the BW pin unconnected, connecting it to the V_{EE} pin or connecting a resistor between the BW pin and the V_{EE} pin.

The LME49610 is fully protected through internal current limit and thermal shutdown.

Key Specifications

■ Low THD+N (V _{OUT} = 3V _{RMS} , f = 1kHz, Fig. 2)	0.00003% (typ)
■ Slew Rate	2000V/μs (typ)
■ High Output Current	250mA (typ)
■ Bandwidth	
BW pin floating	120MHz (typ)
BW connected to V _{EE}	200MHz (typ)
■ Supply Voltage Range	±2.25V ≤ V _{DD} ≤ ±22V

Features

- Pin-selectable bandwidth and quiescent current
- Pure fidelity. Pure performance
- Short circuit protection
- Thermal shutdown
- TO-263 surface-mount package

Applications

- Headphone amplifier output drive stage
- Line drivers
- Low power audio amplifiers
- High-current operational amplifier output stage
- ATE pin driver buffer
- Power supply regulator

Functional Block Diagram

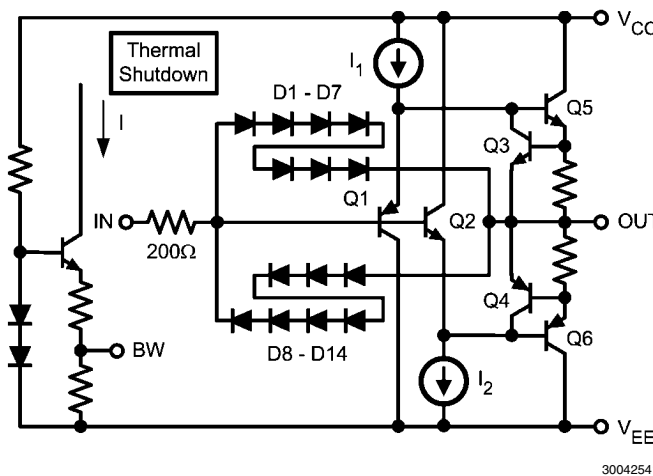
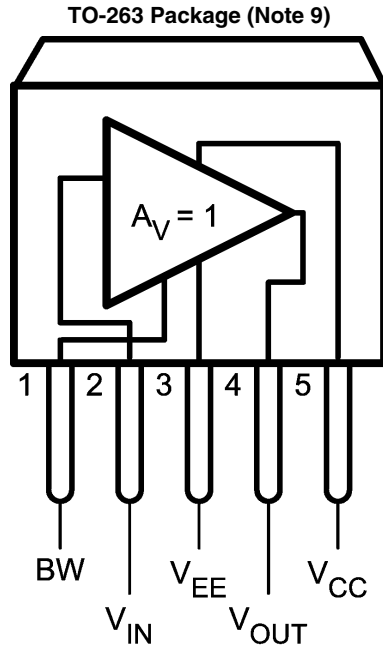

FIGURE 1. Functional Block Diagram

Connection Diagrams



30042539

Top View
Order Number LME49610TS
See NS Package Number TS5B

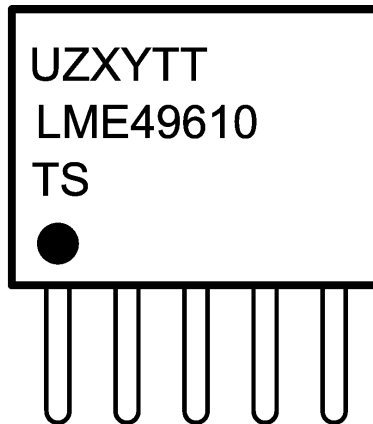

30042542

Top View
U — Wafer fabrication code
Z — Assembly plant
XY — 2 Digit date code
TT — Lot traceability

Absolute Maximum Ratings (Note 1, Note 2)

2)

If Military/Aerospace specified devices are required, please contact the National Semiconductor Sales Office/ Distributors for availability and specifications.

Supply Voltage	46V
ESD Rating (Note 4)	2000V
ESD Rating (Note 5)	200V
Storage Temperature	-40°C to +150°C
Junction Temperature	150°C
Thermal Resistance	

θ_{JC}	4°C/W
θ_{JA}	65°C/W
θ_{JA} (Note 3)	20°C/W
Soldering Information	
TO-263 Package (10 seconds)	260°C

Operating Ratings (Note 1, Note 2)

Temperature Range	
$T_{MIN} \leq T_A \leq T_{MAX}$	-40°C \leq T_A \leq 85°C
Supply Voltage	$\pm 2.25V$ to $\pm 22V$

Electrical Characteristics

The following specifications apply for $V_S = \pm 22V$, $f_{IN} = 1kHz$, $R_L = 1k\Omega$, unless otherwise specified. Typicals and limits apply for $T_A = 25^\circ C$.

Symbol	Parameter	Conditions	LME49610		Units (Limits)
			Typical	Limit	
			(Note 6)	(Note 7)	
I_Q	Total Quiescent Current	$I_{OUT} = 0$			
		BW pin: No connect	13	15	mA (max)
		BW pin: Connected to V_{EE} pin	19	23	mA (max)
THD+N	Total Harmonic Distortion + Noise (Note 8)	$A_V = 1$, $V_{OUT} = 3V_{RMS}$, $R_L = 32\Omega$, BW = 80kHz, closed loop see Figure 2.			
		$f = 1kHz$ $f = 20kHz$	0.000035 0.0005		% %
SR	Slew Rate	$30 \leq BW \leq 180MHz$ $V_{OUT} = 20V_{P-P}$, $R_L = 100\Omega$	2000		V/ μs
BW	Bandwidth	$A_V = -3dB$			
		BW pin: No Connect			
		$R_L = 100\Omega$	110		MHz
		$R_L = 1k\Omega$	120		MHz
		BW pin: Connected to V_{EE} pin			
		$R_L = 100\Omega$	180		MHz
		$R_L = 1k\Omega$	200		MHz
	Voltage Noise Density	$f = 10kHz$ BW pin: No Connect	3.0	8.5	nV/ \sqrt{Hz} (max)
		$f = 10kHz$ BW pin: Connected to V_{EE} pin	2.7	6.5	nV/ \sqrt{Hz} (max)
t_s	Settling Time	$\Delta V = 10V$, $R_L = 100\Omega$ 1% Accuracy			
		BW pin: No connect	200		ns
		BW pin: Connected to V_{EE} pin	60		ns
A_V	Voltage Gain	$V_{OUT} = \pm 10V$			
		$R_L = 67\Omega$	0.93	0.90	V/V (min)
		$R_L = 100\Omega$	0.95	0.92	V/V (min)
		$R_L = 1k\Omega$	0.99	0.98	V/V (min)

Symbol	Parameter	Conditions	LME49610		Units (Limits)
			Typical	Limit	
			(Note 6)	(Note 7)	
V_{OUT}	Voltage Output	Positive			
		$I_{OUT} = 10\text{mA}$	$V_{CC} - 1.2$	$V_{CC} - 1.4$	V (min)
		$I_{OUT} = 100\text{mA}$	$V_{CC} - 1.5$	$V_{CC} - 1.8$	V (min)
		$I_{OUT} = 150\text{mA}$	$V_{CC} - 1.7$	$V_{CC} - 2.1$	V (min)
		Negative			
		$I_{OUT} = -10\text{mA}$	$V_{EE} + 1.2$	$V_{EE} + 1.4$	V (min)
$I_{OUT} = -100\text{mA}$	$V_{EE} + 1.6$	$V_{EE} + 1.9$	V (min)		
$I_{OUT} = -150\text{mA}$	$V_{EE} + 2.2$	$V_{EE} + 2.5$	V (min)		
I_{OUT}	Output Current		± 250		mA
I_{OUT-SC}	Short Circuit Output Current	BW pin: No Connect	± 750		mA
		BW pin: Connected to V_{EE} pin	± 750	± 785	mA (max)
I_B	Input Bias Current	$V_{IN} = 0\text{V}$			
		BW pin: No Connect	± 1.0	± 2.5	μA (max)
		BW pin: Connected to V_{EE} pin	± 3.0	± 5.0	μA (max)
Z_{IN}	Input Impedance	$R_L = 100\Omega$			
		BW pin: No Connect	7.5		$\text{M}\Omega$
		BW pin: Connected to V_{EE} pin	5.5		$\text{M}\Omega$
V_{OS}	Offset Voltage		± 17	± 60	mV (max)
$V_{OS}/^\circ\text{C}$	Offset Voltage vs Temperature	$40^\circ\text{C} \leq T_A \leq +125^\circ\text{C}$	± 100		$\mu\text{V}/^\circ\text{C}$
V_{SUPPLY}	Power Supply Voltage Operating Range		± 2.25		V
			± 22		V

Note 1: "Absolute Maximum Ratings" indicate limits beyond which damage to the device may occur, including inoperability and degradation of device reliability and/or performance. Functional operation of the device and/or non-degradation at the Absolute Maximum Ratings or other conditions beyond those indicated in the *Recommended Operating Conditions* is not implied. The *Recommended Operating Conditions* indicate conditions at which the device is functional and the device should not be operated beyond such conditions. All voltages are measured with respect to the ground pin, unless otherwise specified.

Note 2: The *Electrical Characteristics* tables list guaranteed specifications under the listed *Recommended Operating Conditions* except as otherwise modified or specified by the *Electrical Characteristics Conditions* and/or Notes. Typical specifications are estimations only and are not guaranteed.

Note 3: The maximum power dissipation must be derated at elevated temperatures and is dictated by T_{JMAX} , θ_{JA} , and the ambient temperature, T_A . The maximum allowable power dissipation is $P_{DMAX} = (T_{JMAX} - T_A) / \theta_{JA}$ or the number given in *Absolute Maximum Ratings*, whichever is lower. For the LME49610, typical application shown in *Figure 2* with $|V_{EE}| = V_{CC} = 15\text{V}$, $R_L = 32\Omega$, the total power dissipation is 1.9W. $\theta_{JA} = 20^\circ\text{C}/\text{W}$ for the TO-263 package mounted to 16in² (103.2 cm²) 1oz. copper surface heat sink area.

Note 4: Human body model, applicable std. JESD22-A114C.

Note 5: Machine model, applicable std. JESD22-A115-A.

Note 6: Typical values represent most likely parametric norms at $T_A = +25^\circ\text{C}$, and at the Recommended Operation Conditions at the time of product characterization and are not guaranteed.

Note 7: Datasheet min/max specification limits are guaranteed by test or statistical analysis.

Note 8: This is the distortion of the LME49610 operating in a closed loop configuration with an LME49710. When operating in an operational amplifier's feedback loop, the amplifier's open loop gain dominates, linearizing the system and determining the overall system distortion.

Note 9: The TS5B package is a non-isolated package. The package's metal back and any heat sink to which it is mounted are connected to the same potential as the $-V_{EE}$ pin.

Typical Performance Characteristics

Gain vs Frequency vs Quiescent Current
 $V_S = \pm 22V$

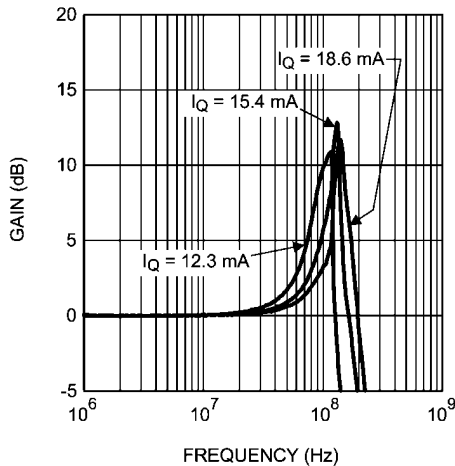

30042570

Phase vs Frequency vs Quiescent Current
 $V_S = \pm 22V$

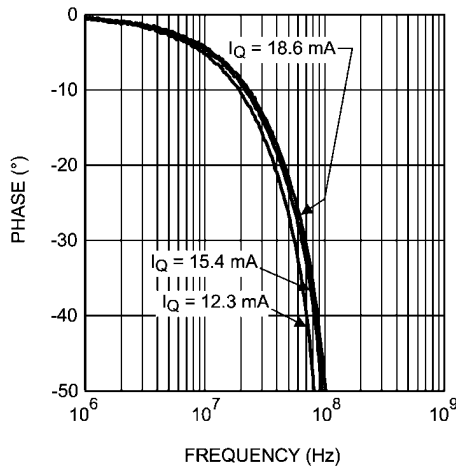

30042571

Gain vs Frequency vs Power Supply Voltage
Wide BW Mode (BW pin = V_{EE})

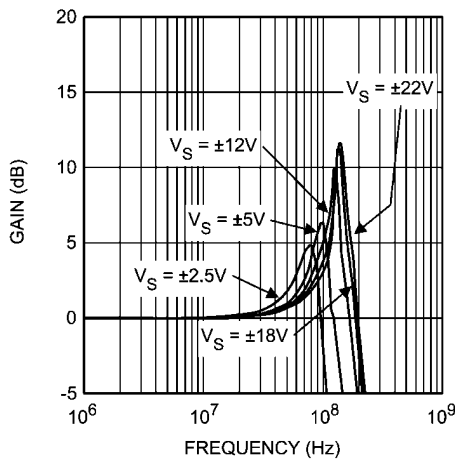

30042572

Phase vs Frequency vs Supply Voltage
Wide BW Mode (BW pin = V_{EE})

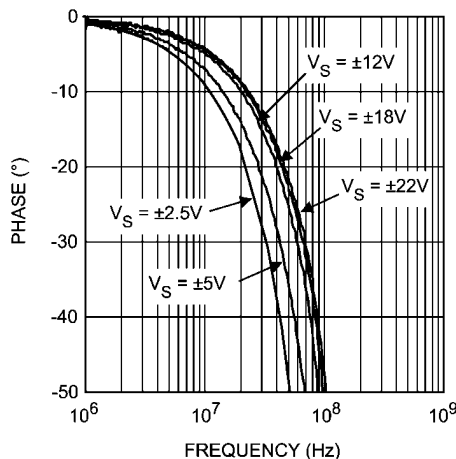

30042573

Gain vs Frequency vs Power Supply Voltage
Low IQ Mode (BW pin = Float)

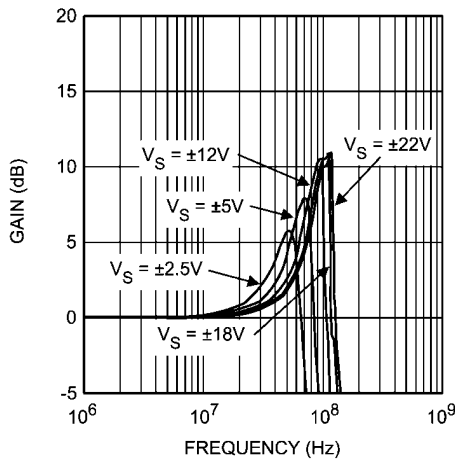

30042574

Phase vs Frequency vs Power Supply Voltage
Low IQ Mode (BW pin = Float)

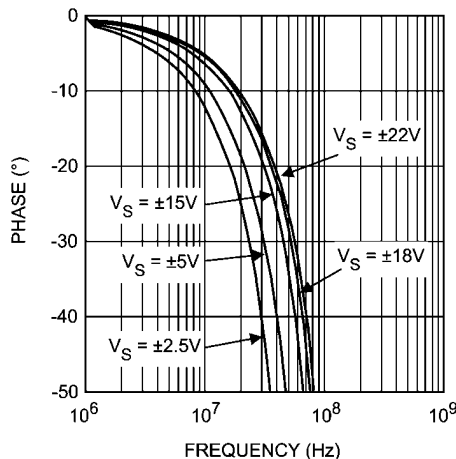

30042575

Gain vs Frequency vs R_{LOAD}
Wide BW Mode (BW pin = V_{EE}), $V_S = \pm 22V$

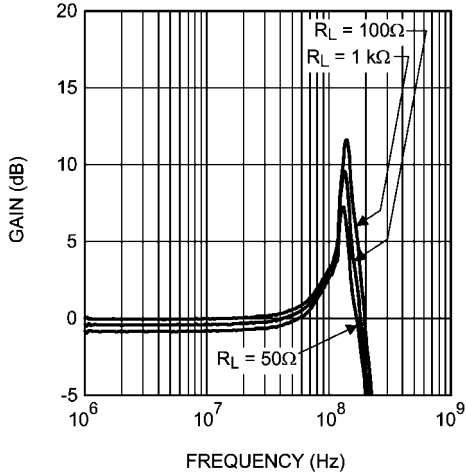

30042576

Phase vs Frequency vs R_{LOAD}
Wide BW Mode (BW pin = V_{EE}), $V_S = \pm 22V$

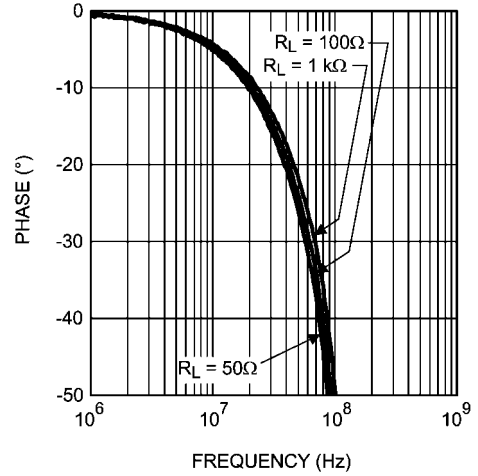

30042577

Gain vs Frequency vs R_{LOAD}
Low I_Q Mode (BW pin = Float), $V_S = \pm 22V$

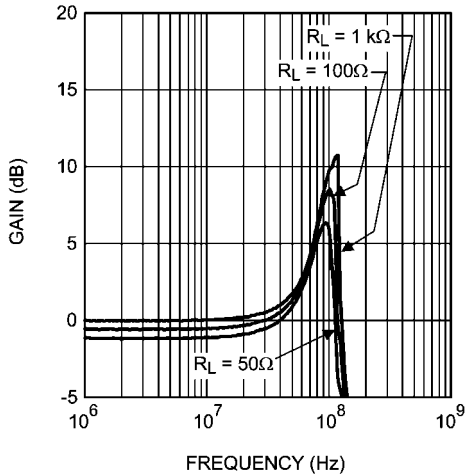

30042578

Phase vs Frequency vs R_{LOAD}
Low I_Q Mode (BW pin = Float), $V_S = \pm 22V$

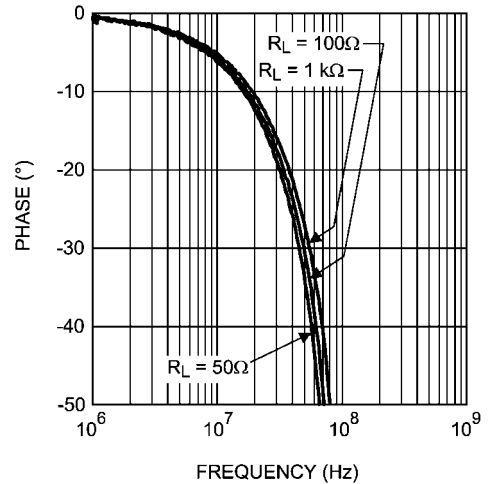

30042579

Gain vs Frequency vs Quiescent Current
 $V_S = \pm 15V$

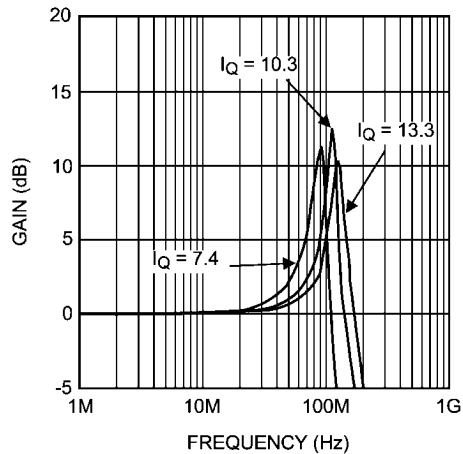

300425a5

Phase vs Frequency vs Quiescent Current
 $V_S = \pm 15V$

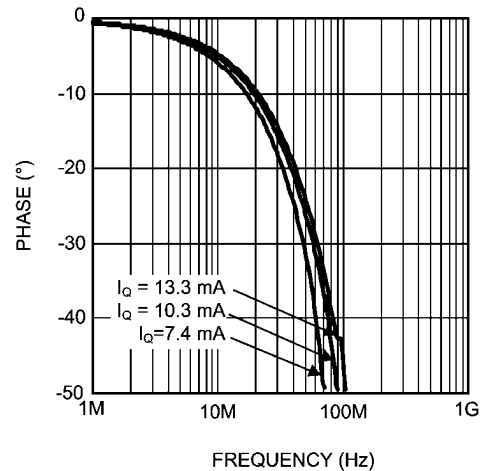

30042594

Gain vs Frequency vs R_{LOAD}
Wide BW Mode (BW pin = V_{EE}), $V_S = \pm 15V$

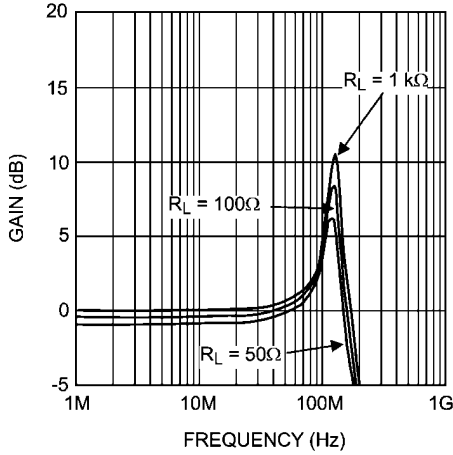

300425a2

Phase vs Frequency vs R_{LOAD}
Wide BW Mode (BW pin = V_{EE}), $V_S = \pm 15V$

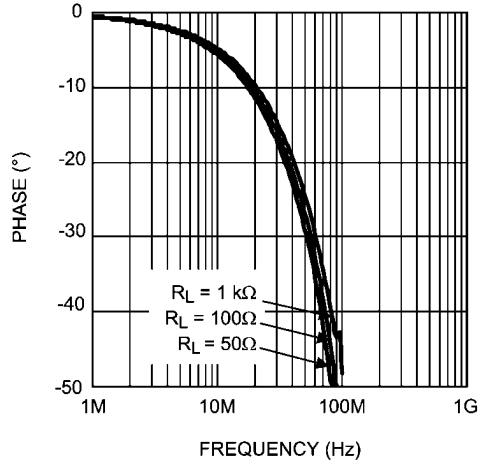

30042591

Gain vs Frequency vs R_{LOAD}
Low I_Q Mode (BW pin = Float), $V_S = \pm 15V$

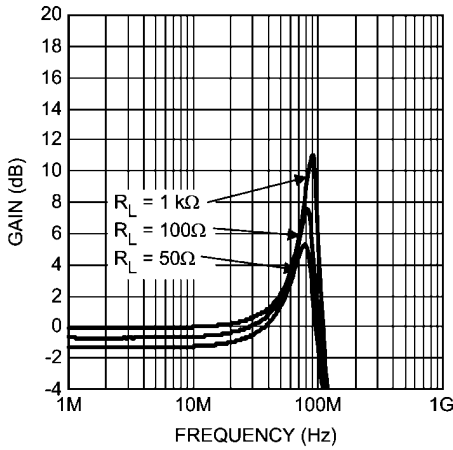

300425a1

Phase vs Frequency vs R_{LOAD}
Low I_Q Mode (BW pin = Float), $V_S = \pm 15V$

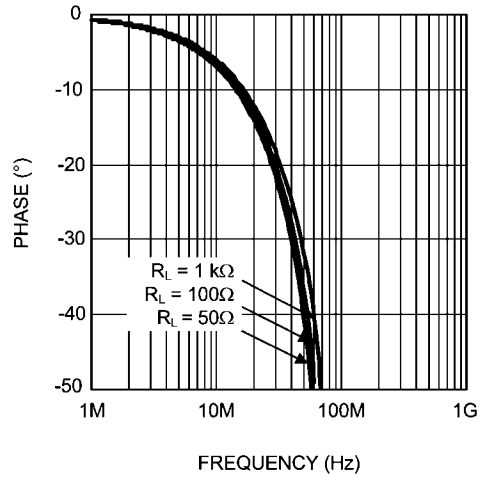

30042590

+PSRR vs Frequency
 $V_S = +15V$ and $\pm 22V$, Wide BW Mode
(BW pin = V_{EE})

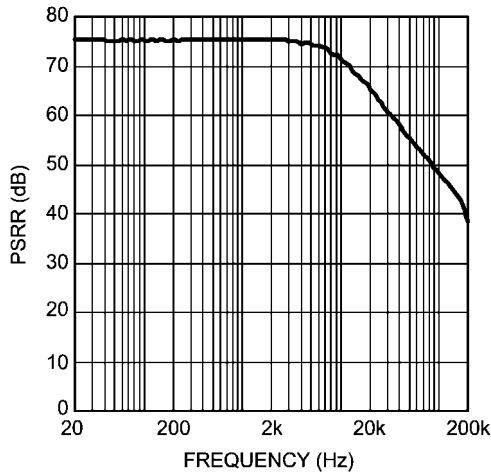

30042597

+PSRR vs Frequency
 $V_S = \pm 15V$ and $\pm 22V$, Low I_Q Mode
(BW pin = Float)

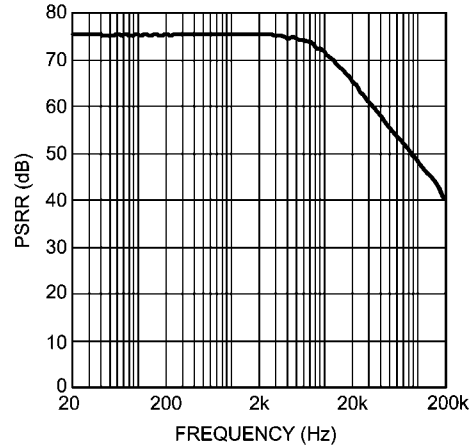

30042595

-PSRR vs Frequency
 $V_S = \pm 15V$ and $\pm 22V$, Wide BW Mode
 (BW pin = V_{EE})

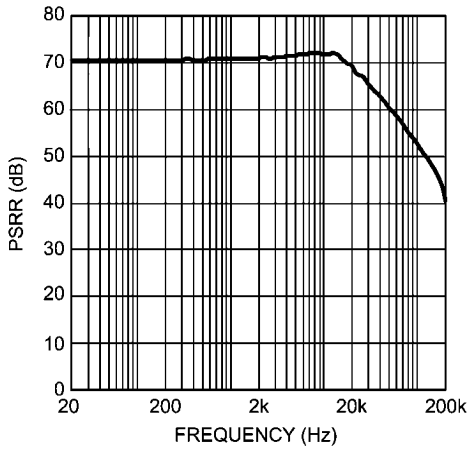

30042598

-PSRR vs Frequency
 $V_S = \pm 15V$ and $\pm 22V$, Low I_Q Mode
 (BW pin = Float)

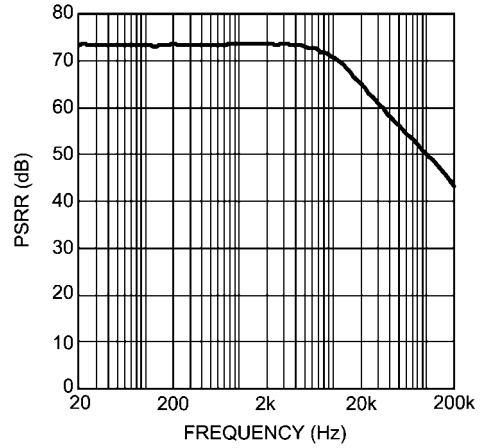

30042596

Quiescent Current vs Bandwidth Control Resistance
 $V_S = \pm 15V$ (Bottom) & $V_S = \pm 22V$ (Top)

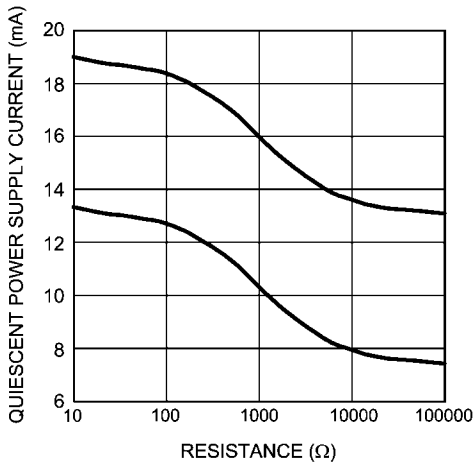

30042585

THD+N vs Output Voltage
 $V_S = \pm 15V$, $R_L = 32\Omega$, $f = 1kHz$

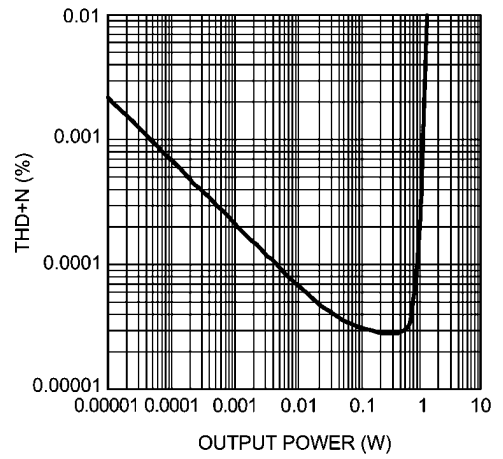

300425a6

Wide BW Noise Curve
 (BW pin = V_{EE})

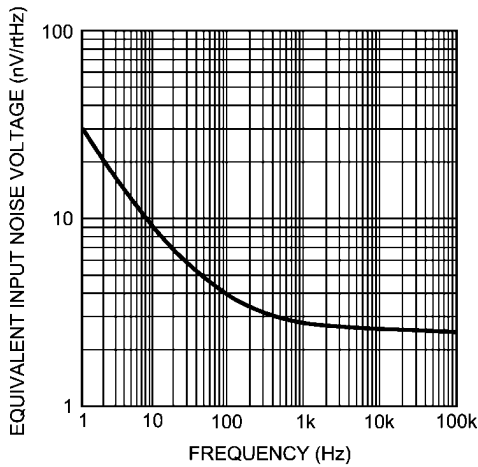

30042586

Low I_Q Noise Curve
 (BW pin = Float)

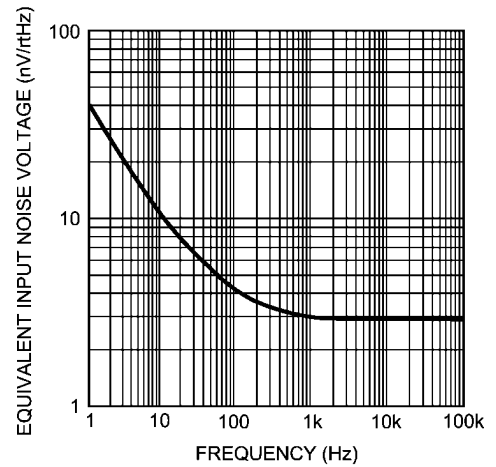

30042587

Typical Application Diagram

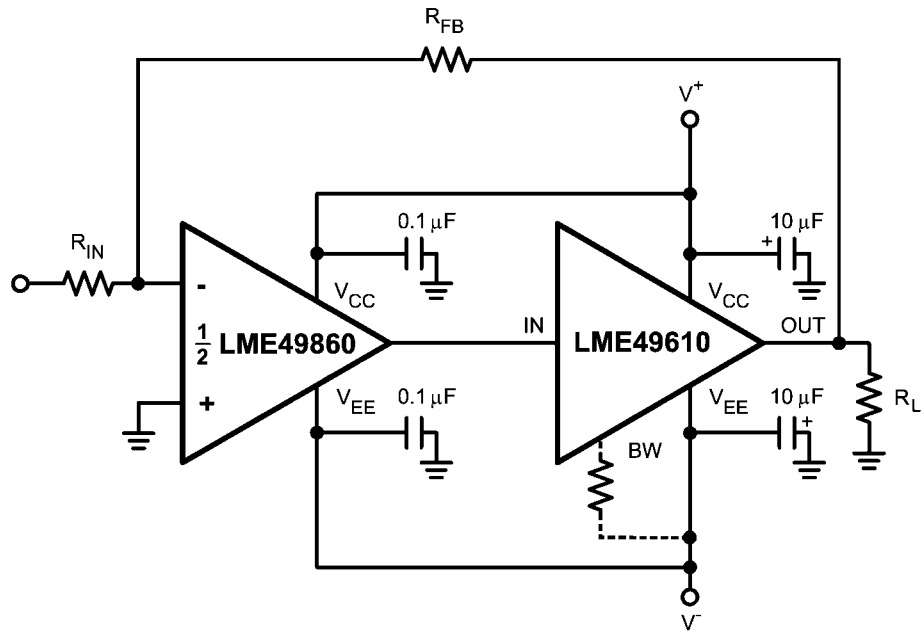

30042540

FIGURE 2. High Performance, High Fidelity LME49610 Audio Buffer Application

Application Information

HIGH PERFORMANCE, HIGH FIDELITY HEADPHONE AMPLIFIER

The LME49610 is the ideal solution for high output, high performance high fidelity headphone amplifiers. When placed in the feedback loop of the LME49710, LME49720 or LME49740 High Performance, High Fidelity audio operational amplifier, the LME49610 is able to drive 32Ω headphones to a dissipation of greater than 500mW at 0.00003% THD+N while operating on $\pm 15V$ power supply voltages. The circuit schematic for a typical headphone amplifier is shown in Figure 3.

Operation

The following describes the circuit operation for the headphone amplifier's Left Channel. The Right Channel operates identically.

The audio input signal is applied to the input jack (HP31 or J1/J2) and dc-coupled to the volume control, VR1. The output signal from VR1's wiper is applied to the non-inverting input of U2-A, an LME49720 High Performance, High Fidelity audio operational amplifier. U2-A's signal gain is set by resistors R2 and R4. To allow for a DC-coupled signal path and to ensure minimal output DC voltage regardless of the closed-loop gain, the other half of the U2 is configured as a DC servo. By constantly monitoring U2-A's output, the servo creates a voltage that compensates for any DC voltage that may be present at the output. A correction voltage is generated and applied to the feedback node at U2-A, pin 2. The servo ensures that the gain at DC is unity. Based on the values shown in Figure 3, the RC combination formed by R11 and C7 sets the servo's high-pass cutoff at 0.16Hz. This is over two decades below 20Hz, minimizing both amplitude and phase perturbations in the audio frequency band's lowest frequencies.

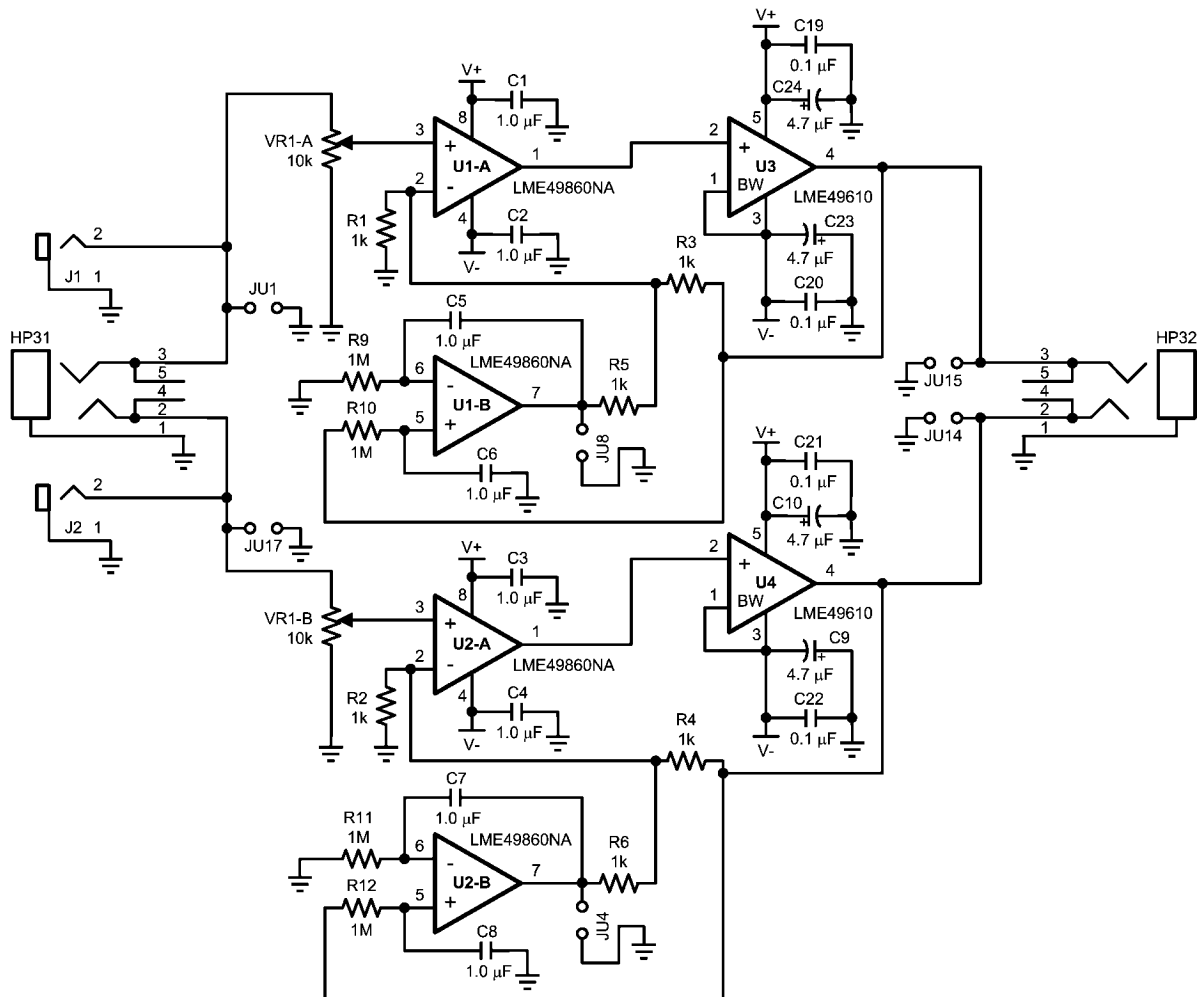

30042558

FIGURE 3. LME49610 delivers high output current for this high performance headphone amplifier

AUDIO BUFFERS

Audio buffers or unity-gain followers, have large current gain and a voltage gain of one. Audio buffers serve many applications that require high input impedance, low output impedance and high output current. They also offer constant gain over a very wide bandwidth.

Buffers serve several useful functions, either in stand-alone applications or in tandem with operational amplifiers. In stand-alone applications, their high input impedance and low output impedance isolates a high impedance source from a low impedance load.

SUPPLY BYPASSING

The LME49610 will place great demands on the power supply voltage source when operating in applications that require fast slewing and driving heavy loads. These conditions can create high amplitude transient currents. A power supply's limited bandwidth can reduce the supply's ability to supply the needed current demands during these high slew rate conditions. This inability to supply the current demand is further exacerbated by PCB trace or interconnecting wire inductance. The transient current flowing through the inductance can produce voltage transients.

For example, the LME49610's output voltage can slew at a typical $2000\text{V}/\mu\text{s}$. When driving a 100Ω load, the di/dt current demand is $20\text{A}/\mu\text{s}$. This current flowing through an inductance of 50nH (approximately $1.5''$ of 22 gage wire) will produce a 1V transient. In these and similar situations, place the parallel combination of a solid $5\mu\text{F}$ to $10\mu\text{F}$ tantalum capacitor and a ceramic $0.1\mu\text{F}$ capacitor as close as possible to the device supply pins.

Ceramic capacitors have very lower ESR (typically less than $10\text{m}\Omega$) and low ESL when compared to the same valued tantalum capacitor. The ceramic capacitors, therefore, have superior AC performance for bypassing high frequency noise.

In less demanding applications that have lighter loads or lower slew rates, the supply bypassing is not as critical. Capacitor values in the range of $0.01\mu\text{F}$ to $0.1\mu\text{F}$ are adequate.

SIMPLIFIED LME49610 CIRCUIT DIAGRAM

The LME49610's simplified circuit diagram is shown in [Figure 4](#). The diagram shows the LME49610's complementary emitter follower design, bias circuit and bandwidth adjustment node.

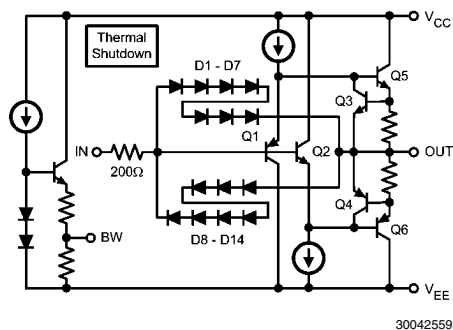
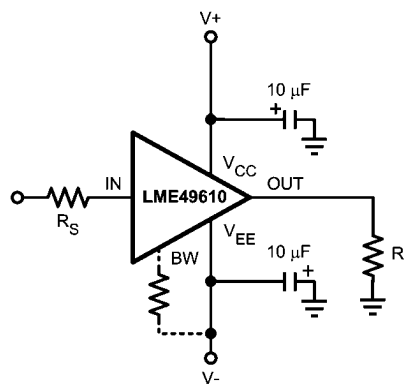

FIGURE 4. Simplified Circuit Diagram

Figure 5 shows the LME49610 connected as an open-loop buffer. The source impedance and optional input resistor, R_S , can alter the frequency response. As previously stated, the power supplies should be bypassed with capacitors con-

nected close to the LME49610's power supply pins. Capacitor values as low as $0.01\mu\text{F}$ to $0.1\mu\text{F}$ will ensure stable operation in lightly loaded applications, but high output current and fast output slewing can demand large current transients from the power supplies. Place a recommended parallel combination of a solid tantalum capacitor in the $5\mu\text{F}$ to $10\mu\text{F}$ range and a ceramic $0.1\mu\text{F}$ capacitor as close as possible to the device supply pins.



30042560

FIGURE 5. Buffer Connections

OUTPUT CURRENT

The LME49610 can continuously source or sink 250mA . Internal circuitry limits the short circuit output current to approximately $\pm 450\text{mA}$. For many applications that fully utilize the LME49610's current source and sink capabilities, thermal dissipation may be the factor that limits the continuous output current.

The maximum output voltage swing magnitude varies with junction temperature and output current. Using sufficient PCB copper area as a heatsink when the metal tab of the LME49610's surface mount TO-263 package is soldered directly to the circuit board reduces thermal impedance. This in turn reduces junction temperature. The PCB copper area should be in the range of 2in^2 to 6in^2 .

THERMAL PROTECTION

LME49610 power dissipated will cause the buffer's junction temperature to rise. A thermal protection circuit in the LME49610 will disable the output when the junction temperature exceeds 150°C . When the thermal protection is activated, the output stage is disabled, allowing the device to cool. The output circuitry is enabled when the junction temperature drops below 150°C .

The TO-263 package has excellent thermal characteristics. To minimize thermal impedance, its exposed die attach paddle should be soldered to a circuit board copper area for good heat dissipation. [Figure 6](#) shows typical thermal resistance from junction to ambient as a function of the copper area. The TO-263's exposed die attach paddle is electrically connected to the V_{EE} power supply pin.

LOAD IMPEDANCE

The LME49610 is stable under any capacitive load when driven by a source that has an impedance of 50Ω or less. When driving capacitive loads, any overshoot that is present on the output signal can be reduced by shunting the load capacitance with a resistor.

OVERVOLTAGE PROTECTION

If the input-to-output differential voltage exceeds the LME49610's Absolute Maximum Rating of 3V, the internal diode clamps shown in Figure 1 conduct, diverting current around the compound emitter followers of Q1/Q5 (D1 – D7 for positive input), or around Q2/Q6 (D8 – D14 for negative inputs). Without this clamp, the input transistors Q1/Q2 and Q5/Q6 will zener and damage the buffer.

To ensure that the current flow through the diodes is held to a safe level, the internal 200Ω resistor in series with the input limits the current through these clamps. If the additional current that flows during this situation can damage the source that drives the LME49610's input, add an external resistor in series with the input see *Figure 5*.

BANDWIDTH CONTROL PIN

The LME49610's –3dB bandwidth is approximately 110MHz in the low quiescent-current mode (13mA typical). Select this mode by leaving the BW pin unconnected.

Connect the BW pin to the V_{EE} pin to extend the LME49610's bandwidth to a nominal value of 180MHz. In this mode, the quiescent current increases to approximately 19mA. Bandwidths between these two limits are easily selected by connecting a series resistor between the BW pin and V_{EE} .

Regardless of the connection to the LME49610's BW pin, the rated output current and slew rate remain constant. With the power supply voltage held constant, the wide-bandwidth mode's increased quiescent current causes a corresponding increase in quiescent power dissipation. For all values of the BW pin voltage, the quiescent power dissipation is equal to the total supply voltage times the quiescent current ($I_Q \cdot (V_{CC} + |V_{EE}|)$).

BOOSTING OP AMP OUTPUT CURRENT

When placed in the feedback loop, the LME49610 will increase an operational amplifier's output current. The operational amplifier's open loop gain will correct any LME49610 errors while operating inside the feedback loop.

To ensure that the operational amplifier and buffer system are closed loop stable, the phase shift must be low. For a system gain of one, the LME49610 must contribute less than 20° at the operational amplifier's unity-gain frequency. Various operating conditions may change or increase the total system phase shift. These phase shift changes may affect the operational amplifier's stability.

Unity gain stability is preserved when the LME49610 is placed in the feedback loop of most general-purpose or precision op amps. When the LME49610 is driving high value capacitive loads, the BW pin should be connected to the V_{EE} pin for wide bandwidth and stable operation. The wide bandwidth mode is also suggested for high speed or fast-settling operational amplifiers. This preserves their stability and the ability to faithfully amplify high frequency, fast-changing signals. Stability is ensured when pulsed signals exhibit no oscillations and ringing is minimized while driving the intended load and operating in the worst-case conditions that perturb the LME49610's phase response.

HIGH FREQUENCY APPLICATIONS

The LME49610's wide bandwidth and very high slew rate make it ideal for a variety of high-frequency open-loop applications such as an ADC input driver, 75Ω stepped volume attenuator driver, and other low impedance loads. Circuit board layout and bypassing techniques affect high frequency, fast signal dynamic performance when the LME49610 operates open-loop.

A ground plane type circuit board layout is best for very high frequency performance results. Bypass the power supply pins (V_{CC} and V_{EE}) with 0.1μF ceramic chip capacitors in parallel with solid tantalum 10μF capacitors placed as close as possible to the respective pins.

Source resistance can affect high-frequency peaking and step response overshoot and ringing. Depending on the signal source, source impedance and layout, best nominal response may require an additional resistance of 25Ω to 200Ω in series with the input. Response with some loads (especially capacitive) can be improved with an output series resistor in the range of 10Ω to 150Ω.

THERMAL MANAGEMENT

Heat Sinking

For some applications, the LME49610 may require a heat sink. The use of a heat sink is dependent on the maximum LME49610 power dissipation and a given application's maximum ambient temperature. In the TO–263 package, heat sinking the LME49610 is easily accomplished by soldering the package's tab to a copper plane on the PCB. (Note: The tab on the LME49610's TO–263 package is electrically connected to V_{EE} .)

Through the mechanisms of convection, heat conducts from the LME49610 in all directions. A large percentage moves to the surrounding air, some is absorbed by the circuit board material and some is absorbed by the copper traces connected to the package's pins. From the PCB material and the copper, it then moves to the air. Natural convection depends on the amount of surface area that contacts the air.

If a heat conductive copper plane has perfect thermal conduction (heat spreading) through the plane's total area, the temperature rise is inversely proportional to the total exposed area. PCB copper planes are, in that sense, an aid to convection. These planes, however, are not thick enough to ensure perfect heat conduction. Therefore, eventually a point of diminishing returns is reached where increasing copper area offers no additional heat conduction to the surrounding air. This is apparent in *Figure 6*. 2 oz copper boards will have decrease thermal resistance providing a better heat sink compared to 1oz. copper. Beyond 1oz or 2oz copper plane areas, external heatsinks are required. Ultimately, the 1oz copper

area attains a nominal value of 20°C/W junction to ambient thermal resistance (θ_{JA}) under zero air flow.

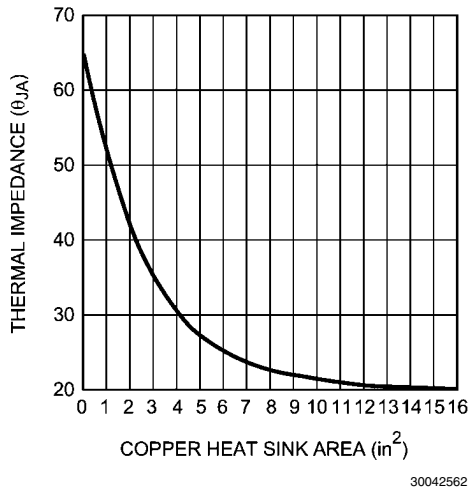

FIGURE 6. Thermal Resistance (typ) for 5 lead TO-263 Package Mounted on 1oz. copper

A copper plane may be placed directly beneath the tab. Additionally, a matching plane can be placed on the opposite side. If a plane is placed on the side opposite of the LME49610, connect it to the plane to which the buffer's metal tab is soldered with a matrix of thermal vias per JEDEC Standard JESD51-5.

Determining Copper Area

Find the required copper heat sink area using the following guidelines:

1. Determine the maximum power dissipation of the LME49610, P_D .
2. Specify a maximum operating ambient temperature, T_A ($T_{A(MAX)}$). Note that the die temperature, T_J , will be higher than T_A by an amount that is dependent on the thermal resistance from junction to ambient, θ_{JA} . Therefore, T_A must be specified such that T_J does not exceed the absolute maximum die temperature of 150°C.
3. Specify a maximum allowable junction temperature, T_J ($T_{J(MAX)}$). This is the LME49610's die temperature when the buffer is drawing maximum current (quiescent and load). It is prudent to design for a maximum continuous junction temperature of 100°C to 130°C. Ensure, however, that the junction temperature never exceeds the 150°C absolute maximum rating for the part.
4. Calculate the value of junction to ambient thermal resistance, θ_{JA} .
5. θ_{JA} as a function of copper area in square inches is shown in [Figure 6](#). Choose a copper area that will guarantee the specified $T_{J(MAX)}$ for the calculated θ_{JA} . The maximum value of junction to ambient thermal resistance, θ_{JA} , is defined as:

$$\theta_{JA} = (T_{J(MAX)} - T_{A(MAX)}) / P_{D(MAX)} \quad (^\circ\text{C/W}) \quad (1)$$

where:

$T_{J(MAX)}$ = the maximum recommended junction temperature

$T_{A(MAX)}$ = the maximum ambient temperature in the LME49610's environment

$P_{D(MAX)}$ = the maximum recommended power dissipation

Note: The allowable thermal resistance is determined by the maximum allowable temperature increase:

$$T_{RISE} = T_{J(MAX)} - T_{A(MAX)}$$

Thus, if ambient temperature extremes force T_{RISE} to exceed the design maximum, the part must be de-rated by either decreasing P_D to a safe level, reducing θ_{JA} further, or, if available, using a larger copper area.

Procedure

1. First determine the maximum power dissipated by the LME49610, $P_{D(MAX)}$. For the simple case of the buffer driving a resistive load, and assuming equal supplies, $P_{D(MAX)}$ is given by:

$$P_{D(MAX)(AC)} = (I_S \times V_S) + (V_S)^2 / (2\pi^2 R_L) \quad (\text{Watts}) \quad (2)$$

$$P_{D(MAX)(DC)} = (I_S \times V_S) + (V_S)^2 / R_L \quad (\text{Watts}) \quad (3)$$

where:

$$V_S = |V_{EE}| + V_{CC} \quad (\text{V})$$

$$I_S = \text{quiescent supply current (A)}$$

Equation (2) is for sinusoidal output voltages and (3) is for DC output voltages

2. Determine the maximum allowable die temperature rise,

$$T_{RISE(MAX)} = T_{J(MAX)} - T_{A(MAX)} \quad (^\circ\text{C}) \quad (4)$$

3. Using the calculated value of $T_{RISE(MAX)}$ and $P_{D(MAX)}$, find the required value of junction to ambient thermal resistance combining equation 1 and equation 4 to derive equation 5:

$$\theta_{JA} = T_{RISE(MAX)} / P_{D(MAX)} \quad (^\circ\text{C/W}) \quad (5)$$

4. Finally, choose the minimum value of copper area from [Figure 6](#) based on the value for θ_{JA} .

Example

Assume the following conditions: $V_S = |V_{EE}| + V_{CC} = 30\text{V}$, $R_L = 32\Omega$, $I_S = 15\text{mA}$, sinusoidal output voltage, $T_{J(MAX)} = 125^\circ\text{C}$, $T_{A(MAX)} = 85^\circ\text{C}$.

Applying Equation (2):

$$\begin{aligned} P_{D(MAX)} &= (I_S \times V_S) + (V_S)^2 / 2\pi^2 R_L \\ &= (15\text{mA})(30\text{V}) + 900\text{V}^2 / 632\Omega \\ &= 1.87\text{W} \end{aligned}$$

Applying Equation (4):

$$\begin{aligned} T_{RISE(MAX)} &= 125^\circ\text{C} - 85^\circ\text{C} \\ &= 40^\circ\text{C} \end{aligned}$$

Applying Equation (5):

$$\begin{aligned}\theta_{JA} &= 40^{\circ}\text{C}/1.87\text{W} \\ &= 21.4^{\circ}\text{C}/\text{W}\end{aligned}$$

Examining the Copper Area vs. θ_{JA} plot (see [Figure 6](#)) indicates that a thermal resistance of $21.4^{\circ}\text{C}/\text{W}$ is possible with a $8\text{--}10\text{in}^2$ plane of one layer of 1oz copper. Other solutions include using two layers of 1oz copper or the use of 2oz copper. Higher dissipation may require forced air flow. As a safety margin, an extra 15% heat sinking capability is recommended.

When amplifying AC signals, wave shapes and the nature of the load (reactive, non-reactive) also influence dissipation. Peak dissipation can be several times the average with reactive loads. It is particularly important to determine dissipation when driving large load capacitance.

The LME49610's dissipation in DC circuit applications is easily computed using Equation (3). After the value of dissipation is determined, the heat sink copper area calculation is the same as for AC signals.

SLEW RATE

A buffer's voltage slew rate is its output signal's rate of change with respect to an input signal's step changes. For resistive loads, slew rate is limited by internal circuit capacitance and operating current (in general, the higher the operating current for a given internal capacitance, the higher the slew rate).

However, when driving capacitive loads, the slew rate may be limited by the available peak output current according to the following expression.

$$dv/dt = I_{PK} / C_L \quad (6)$$

Output voltages with high slew rates will require large output load currents. For example if the part is required to slew at $1000\text{V}/\mu\text{s}$ with a load capacitance of 1nF , the current demanded from the LME49610 is 1A . Therefore, fast slew rate is incompatible with a capacitive load of this value. Also, if C_L is in parallel with the load, the peak current available to the load decreases as C_L increases.

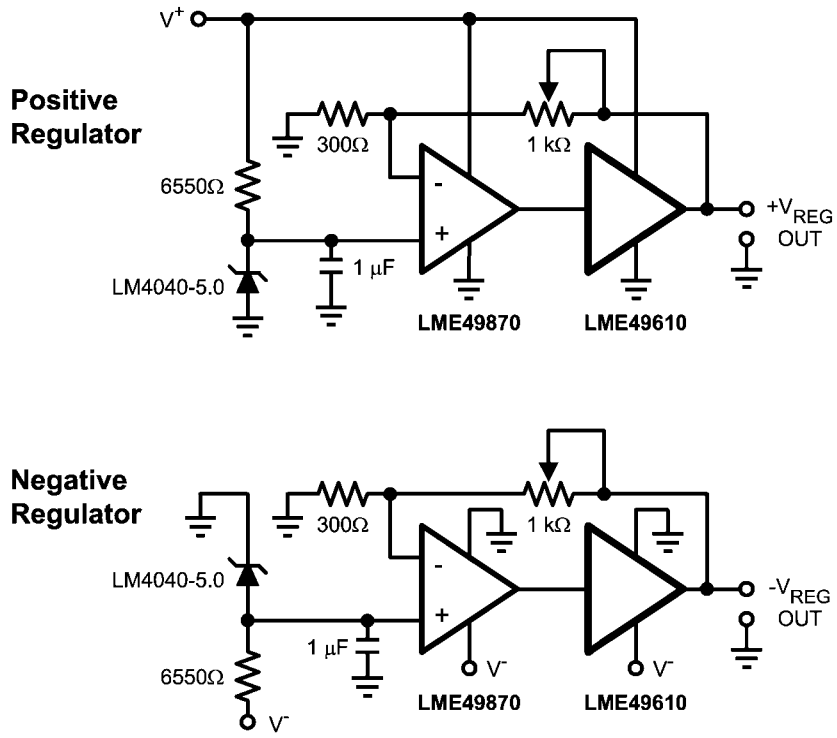

300425a7

FIGURE 7. High Speed Positive and Negative Regulator

Revision History

Rev	Date	Description
1.0	04/09/08	Initial WEB released.
1.01	10/28/09	Typical and Limit changes on the Short Circuit Output current.

Physical Dimensions inches (millimeters) unless otherwise noted

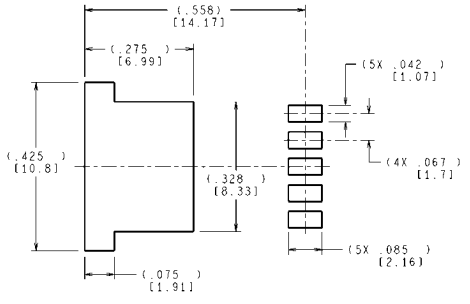
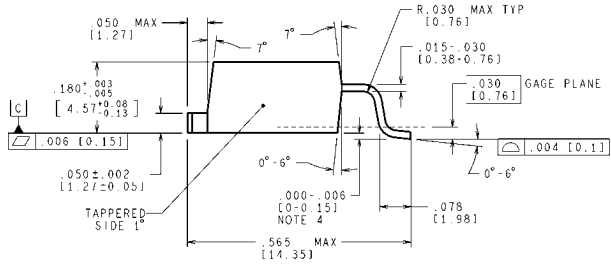
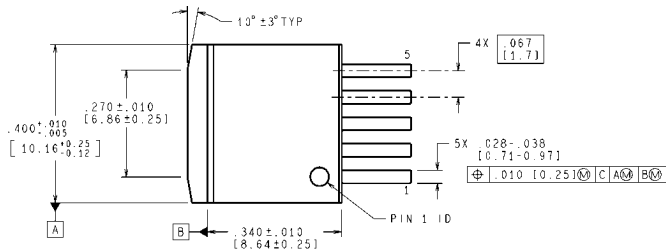

LAND PATTERN RECOMMENDATION

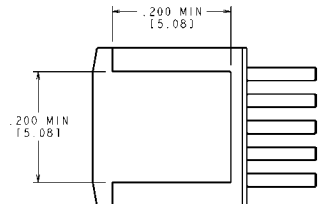

CONTROLLING DIMENSION IS INCH
VALUES IN [] ARE MILLIMETERS
DIMENSIONS IN () FOR REFERENCE ONLY

Order Number LME49610TS
See NS Package TS5B

TS5B (Rev D)

Notes

For more National Semiconductor product information and proven design tools, visit the following Web sites at:

Products		Design Support	
Amplifiers	www.national.com/amplifiers	WEBENCH® Tools	www.national.com/webench
Audio	www.national.com/audio	App Notes	www.national.com/appnotes
Clock and Timing	www.national.com/timing	Reference Designs	www.national.com/refdesigns
Data Converters	www.national.com/adc	Samples	www.national.com/samples
Interface	www.national.com/interface	Eval Boards	www.national.com/evalboards
LVDS	www.national.com/lvds	Packaging	www.national.com/packaging
Power Management	www.national.com/power	Green Compliance	www.national.com/quality/green
Switching Regulators	www.national.com/switchers	Distributors	www.national.com/contacts
LDOs	www.national.com/ldo	Quality and Reliability	www.national.com/quality
LED Lighting	www.national.com/led	Feedback/Support	www.national.com/feedback
Voltage Reference	www.national.com/vref	Design Made Easy	www.national.com/easy
PowerWise® Solutions	www.national.com/powerwise	Solutions	www.national.com/solutions
Serial Digital Interface (SDI)	www.national.com/sdi	Mil/Aero	www.national.com/milaero
Temperature Sensors	www.national.com/tempensors	SolarMagic™	www.national.com/solarmagic
Wireless (PLL/VCO)	www.national.com/wireless	PowerWise® Design University	www.national.com/training

THE CONTENTS OF THIS DOCUMENT ARE PROVIDED IN CONNECTION WITH NATIONAL SEMICONDUCTOR CORPORATION ("NATIONAL") PRODUCTS. NATIONAL MAKES NO REPRESENTATIONS OR WARRANTIES WITH RESPECT TO THE ACCURACY OR COMPLETENESS OF THE CONTENTS OF THIS PUBLICATION AND RESERVES THE RIGHT TO MAKE CHANGES TO SPECIFICATIONS AND PRODUCT DESCRIPTIONS AT ANY TIME WITHOUT NOTICE. NO LICENSE, WHETHER EXPRESS, IMPLIED, ARISING BY ESTOPPEL OR OTHERWISE, TO ANY INTELLECTUAL PROPERTY RIGHTS IS GRANTED BY THIS DOCUMENT.

TESTING AND OTHER QUALITY CONTROLS ARE USED TO THE EXTENT NATIONAL DEEMS NECESSARY TO SUPPORT NATIONAL'S PRODUCT WARRANTY. EXCEPT WHERE MANDATED BY GOVERNMENT REQUIREMENTS, TESTING OF ALL PARAMETERS OF EACH PRODUCT IS NOT NECESSARILY PERFORMED. NATIONAL ASSUMES NO LIABILITY FOR APPLICATIONS ASSISTANCE OR BUYER PRODUCT DESIGN. BUYERS ARE RESPONSIBLE FOR THEIR PRODUCTS AND APPLICATIONS USING NATIONAL COMPONENTS. PRIOR TO USING OR DISTRIBUTING ANY PRODUCTS THAT INCLUDE NATIONAL COMPONENTS, BUYERS SHOULD PROVIDE ADEQUATE DESIGN, TESTING AND OPERATING SAFEGUARDS.

EXCEPT AS PROVIDED IN NATIONAL'S TERMS AND CONDITIONS OF SALE FOR SUCH PRODUCTS, NATIONAL ASSUMES NO LIABILITY WHATSOEVER, AND NATIONAL DISCLAIMS ANY EXPRESS OR IMPLIED WARRANTY RELATING TO THE SALE AND/OR USE OF NATIONAL PRODUCTS INCLUDING LIABILITY OR WARRANTIES RELATING TO FITNESS FOR A PARTICULAR PURPOSE, MERCHANTABILITY, OR INFRINGEMENT OF ANY PATENT, COPYRIGHT OR OTHER INTELLECTUAL PROPERTY RIGHT.

LIFE SUPPORT POLICY

NATIONAL'S PRODUCTS ARE NOT AUTHORIZED FOR USE AS CRITICAL COMPONENTS IN LIFE SUPPORT DEVICES OR SYSTEMS WITHOUT THE EXPRESS PRIOR WRITTEN APPROVAL OF THE CHIEF EXECUTIVE OFFICER AND GENERAL COUNSEL OF NATIONAL SEMICONDUCTOR CORPORATION. As used herein:

Life support devices or systems are devices which (a) are intended for surgical implant into the body, or (b) support or sustain life and whose failure to perform when properly used in accordance with instructions for use provided in the labeling can be reasonably expected to result in a significant injury to the user. A critical component is any component in a life support device or system whose failure to perform can be reasonably expected to cause the failure of the life support device or system or to affect its safety or effectiveness.

National Semiconductor and the National Semiconductor logo are registered trademarks of National Semiconductor Corporation. All other brand or product names may be trademarks or registered trademarks of their respective holders.

Copyright© 2009 National Semiconductor Corporation

For the most current product information visit us at www.national.com



National Semiconductor Americas Technical Support Center
 Email: support@nsc.com
 Tel: 1-800-272-9959

National Semiconductor Europe Technical Support Center
 Email: europe.support@nsc.com

National Semiconductor Asia Pacific Technical Support Center
 Email: ap.support@nsc.com

National Semiconductor Japan Technical Support Center
 Email: jpn.feedback@nsc.com

IMPORTANT NOTICE

Texas Instruments Incorporated and its subsidiaries (TI) reserve the right to make corrections, modifications, enhancements, improvements, and other changes to its products and services at any time and to discontinue any product or service without notice. Customers should obtain the latest relevant information before placing orders and should verify that such information is current and complete. All products are sold subject to TI's terms and conditions of sale supplied at the time of order acknowledgment.

TI warrants performance of its hardware products to the specifications applicable at the time of sale in accordance with TI's standard warranty. Testing and other quality control techniques are used to the extent TI deems necessary to support this warranty. Except where mandated by government requirements, testing of all parameters of each product is not necessarily performed.

TI assumes no liability for applications assistance or customer product design. Customers are responsible for their products and applications using TI components. To minimize the risks associated with customer products and applications, customers should provide adequate design and operating safeguards.

TI does not warrant or represent that any license, either express or implied, is granted under any TI patent right, copyright, mask work right, or other TI intellectual property right relating to any combination, machine, or process in which TI products or services are used. Information published by TI regarding third-party products or services does not constitute a license from TI to use such products or services or a warranty or endorsement thereof. Use of such information may require a license from a third party under the patents or other intellectual property of the third party, or a license from TI under the patents or other intellectual property of TI.

Reproduction of TI information in TI data books or data sheets is permissible only if reproduction is without alteration and is accompanied by all associated warranties, conditions, limitations, and notices. Reproduction of this information with alteration is an unfair and deceptive business practice. TI is not responsible or liable for such altered documentation. Information of third parties may be subject to additional restrictions.

Resale of TI products or services with statements different from or beyond the parameters stated by TI for that product or service voids all express and any implied warranties for the associated TI product or service and is an unfair and deceptive business practice. TI is not responsible or liable for any such statements.

TI products are not authorized for use in safety-critical applications (such as life support) where a failure of the TI product would reasonably be expected to cause severe personal injury or death, unless officers of the parties have executed an agreement specifically governing such use. Buyers represent that they have all necessary expertise in the safety and regulatory ramifications of their applications, and acknowledge and agree that they are solely responsible for all legal, regulatory and safety-related requirements concerning their products and any use of TI products in such safety-critical applications, notwithstanding any applications-related information or support that may be provided by TI. Further, Buyers must fully indemnify TI and its representatives against any damages arising out of the use of TI products in such safety-critical applications.

TI products are neither designed nor intended for use in military/aerospace applications or environments unless the TI products are specifically designated by TI as military-grade or "enhanced plastic." Only products designated by TI as military-grade meet military specifications. Buyers acknowledge and agree that any such use of TI products which TI has not designated as military-grade is solely at the Buyer's risk, and that they are solely responsible for compliance with all legal and regulatory requirements in connection with such use.

TI products are neither designed nor intended for use in automotive applications or environments unless the specific TI products are designated by TI as compliant with ISO/TS 16949 requirements. Buyers acknowledge and agree that, if they use any non-designated products in automotive applications, TI will not be responsible for any failure to meet such requirements.

Following are URLs where you can obtain information on other Texas Instruments products and application solutions:

Products

Audio	www.ti.com/audio
Amplifiers	amplifier.ti.com
Data Converters	dataconverter.ti.com
DLP® Products	www.dlp.com
DSP	dsp.ti.com
Clocks and Timers	www.ti.com/clocks
Interface	interface.ti.com
Logic	logic.ti.com
Power Mgmt	power.ti.com
Microcontrollers	microcontroller.ti.com
RFID	www.ti-rfid.com
OMAP Mobile Processors	www.ti.com/omap
Wireless Connectivity	www.ti.com/wirelessconnectivity

Applications

Communications and Telecom	www.ti.com/communications
Computers and Peripherals	www.ti.com/computers
Consumer Electronics	www.ti.com/consumer-apps
Energy and Lighting	www.ti.com/energy
Industrial	www.ti.com/industrial
Medical	www.ti.com/medical
Security	www.ti.com/security
Space, Avionics and Defense	www.ti.com/space-avionics-defense
Transportation and Automotive	www.ti.com/automotive
Video and Imaging	www.ti.com/video

TI E2E Community Home Page

e2e.ti.com

Mailing Address: Texas Instruments, Post Office Box 655303, Dallas, Texas 75265
Copyright © 2011, Texas Instruments Incorporated