

Vacuum tube 12BH7AEH gold is a miniature twin triode with equipotential cathodes, designed to amplify low frequency voltage in radio engineering devices.

Pin arrangement

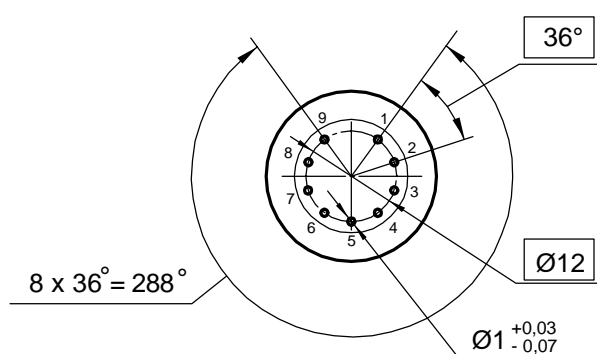

Electrode -to - lead connection diagram

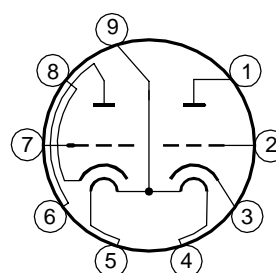

Dimensions

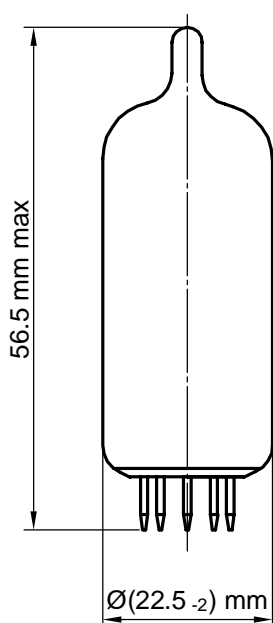

Lead designation	Name of electrode
1	Second triode plate
2	Second triode grid
3	Second triode cathode
4, 5, 9	Heater
6	First triode plate
7	First triode grid
8	First triode cathode

Electrical parameters

Parameters, conditions and units	Nominal	
	min	max
Heater current, mA at: filament voltage 6.3 V at: filament voltage 12.6 V	550 275	680 340
Grid reverse current, μA , (at: filament voltage 6.3 V or 12.6 V, plate voltage 250 V, grid voltage minus 10.5 V, resistance in grid circuit 0.25 M Ω)	—	0.2
Plate current, mA, (at: filament voltage 6.3 V or 12.6 V, plate voltage 250 V, grid voltage minus 10.5 V)	9.0	16.0
First and second triodes plate current difference, % (at: filament voltage 6.3 V or 12.6 V, plate voltage 250 V, grid voltage minus 10.5 V)	—	± 30
Slope of characteristic, mA/V (at: filament voltage 6.3 V or 12.6 V, plate voltage 250 V, grid voltage minus 10.5 V)	2.4	4.0
Amplification factor (at: filament voltage 6.3 V or 12.6 V, plate voltage 250 V, grid voltage minus 10.5 V)	14	—
Cathode - heater insulation resistance, M Ω (at: filament voltage 6.3 V or 12.6 V, cathode - heater voltage ± 200 V)	10	—
Plate current at the beginning of the characteristic, μA (at: filament voltage 6.3 V or 12.6 V, plate voltage 250 V, grid voltage minus 23.0 V)	—	80

Maximum permissible operating conditions

Parameters, units	Nominal	
	min	max
Filament voltage, V for parallel connection for series connection	6 12	6.6 13.2
Plate voltage, V	—	300
Cathode - heater voltage, V	—	± 200
Power dissipation at the plate of each triode, W	—	3.5
Cathode current, mA	—	20
Grid circuit resistance for each of the triodes, M Ω fixed bias self - bias	— —	0.25 1.0

