

All dimensions in mm

Component list

1	Base element Ultrad ¹	1
2	Signal conductor, Ag fine silver	1
3	Reinforcement, VA	1
4	Pressure nut Ultrad ¹	1
5	Pressure nut cap, Ms	1
6	Pressure ring Makrolon ²	1
7	Damping ring	1
8	Marking ring, PA	1
9	Covering ring, Ms	1
10	Double step washer, PA	1
11	Counter nut Ultrad ¹	1

Extent of delivery 1 – 11 mounted

Revision date 14.01.2009 13:01

¹⁾ Ultrad is a reg. trademark of Albis Plastic GmbH • ²⁾ Makrolon is a reg. trademark of Bayer AG • ³⁾ Elastolan 95 is a reg. trademark of Elastolan AB
• WBT und nextgen are reg. trademarks of WBT GmbH

WBT-0705 nextgen™ Pole Terminal

(Internat. Patent and Design Patents EP 1 470 620, EU 953 849)
Pole terminal for cabinet wall mounting, *plug- / solder version*

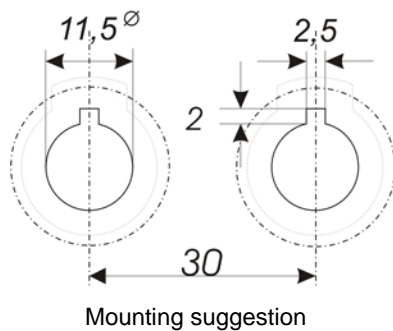

WBT- 0705 Ag
RoHS compliant

1. Mechanics

- One piece, low tolerance contact element
- Fully insulated construction

2. Materials

- Signal conductor (2) fine silver
- Base element (1) Ultrad¹, PA mineralized, fibre-glass reinforced
- Counter nut (11) and Pressure nut (4) Ultrad¹, PA, fibre-glass reinforced
- Marking ring (8) and Double step washer (10) PA 6.6
- Damping ring (7) Elastolan 95³
- Pressure ring (6) Makrolon²
- Pressure nut cup (5), Covering ring (9) brass
- Reinforcement (3) stainless steel, non ferromagnetic

3. Surfaces

- Signal conductor passivated, nickel-free, non ferromagnetic
- Pressure nut cup, covering ring Pd 0.5 µm
- all metallic parts are free from substances with ferromagnetic properties

4. Operating Characteristics (reliably observed after more than 10³ connections/disconnections)

- Permanent current $I_D \geq 30$ A
- Peak current $I_S \geq 200$ A
- Transition resistance $R_{Di} < 0.1$ mOhm (measured with spade connection)
- Contact resistance $R_{DAg} < 0.14$ mOhm (measured with spade connection)
- Insulation resistance $R_{iso} > 10^{10}$ Ohm (500 V)

5. Connection Options

- solder (optimal for cable up to 4 mm²/11 AWG)
- plug (for 6.3 mm flat push-on cable shoe)

6. Mounting

- Chassis drill hole $\varnothing 11.5^{+0.2}$ mm with slot 2.5x2 mm for twist prevention (see drilling scheme)
- For wall thickness from 0.9 to 10 mm. With puzzle plate (s. picture on left) WBT-9410: from 0.9 to 8 mm
- Recommended distance between two terminal centres: 30 mm
- Recommended tightening torque for the counter nut (11): 1.8 Nm